



# WHIRLPOOL BATH PUMP INSTRUCTION MANUAL WP SERIES PUMPS

## IMPORTANT SAFETY INSTRUCTIONS

When installing and using this electrical equipment, basic safety precautions should always be followed, including the following:

**1.READ AND FOLLOW ALL INSTRUCTIONS**

**2.WARNING** To reduce the risk of injury. Do not permit children to use this product unless they are closely supervised at all times.

**3.WARNING** Risk of Electrical Shock . Connected only to grounding type receptacle protected by a ground fault circuit interrupter (GFCI). Contact a qualified electrician if you cannot verify that the receptacle is protected by GFCI.

**4.CAUTION** Do not bury cord. Locate cord to minimize abuse from lawnmowers, hedge trimmers, and other equipment.

**5.CAUTION** In case the running parts will injure people, don't make the electric pump running before then pipeline have been connected.

**6.WARNING** To reduce the risk of electrical shock, replace damaged cord immediately.

**7.WARNING** To reduce the risk of electrical shock, do not use extension cord to connect unit electric supply; provide a properly located outlet.

**8.CAUTION** This pump is for used for fix-installed bath tub, It is not suitable for swimming pool spa.

9.Do not install within an outer enclosure or beneath the skirt of a hot tub unless so marked.

**10.**This appliance is not intended for use by young children or infirm persons unless they have been adequately supervised by a responsible person to ensure that they can use the appliance safely.

**11.**Young children should be supervised to ensure that they do not play with the appliance.

**12.FOR INDOOR USE ONLY.**

**13.SAVE THESE INSTRUCTIONS.**



This product must not be disposed together with the domestic waste. This product has to be disposed at an authorized place for recycling of electrical and electronic appliances.

By collecting and recycling waste, you help save natural resources, and make sure the product is disposed in an environmental friendly and healthy way.

## 1.GENERAL

– These instructions are for correct installation, and optimum performance of the bath pumps, so they should be read carefully.

– These are single - stage centrifugal pumps designed to operate with compact hydromassage equipment, They are equipped with a total emptying system to prevent the discharge of residual liquid in each stopping.

– V/Hz esp: See pump nameplate.

– These units are designed to operate with clean water at a maximum water temperature of 50°C.

– Storage temperature: -10°C ~ +50°C. Relative Air Humidity:95% Max.

– Built of top quality materials, they are subjected to strict hydraulic and electrical controls and are carefully verified.

– Correct installation is ensured by following these instructions and those of the wiring diagram; otherwise, overloads may be produced in the motor. We decline responsibility for any damage caused by not following these instructions.

## 2.INSTALLATION

– Pumps must be level installed, Dimensions and position of the pump for supporting and fixing the pump within this space (Fig.3).

– Pump must be fixed by screw on the tub shelf, and fixed with silent block to lower the noise and vibration. Sticking and enlacing is forbidden.

– The pump will be getting hot in operating, to speed up cooling, the minimum distance between the motor of the pump and the surrounding structure should not be less than 20mm.

– The suction, pipe of the pump should be as short as possible.

– The rating Label must be visible after installation.

– Parts containing live parts, except parts supplied with safety extra low voltage <12V, must be inaccessible to a person in the bath.

– Class I appliances must be permanently connected to fixed wiring. Part including electrical components except remote control devices must be located or fixed so that they cannot enter the bath.

## 3.PIPE ASSEMBLY

– The maximum inlet water pressure  $\leq 0.15$ MPa.

– The suction pipes should have a diameter equal to or larger than of the discharge pipes. It can avoid the loss of the head and improve the efficiency.

– The suction and discharge pipes should not rest above the pump in any case.

– Seal all the connectors and unions well. Avoid any dripping on the motor, which would unfailingly damage it.

– Should be use the new hose module which supplements along with the bathtub, the old hose module cannot be reused.

## 4.ELECTRICAL CONNECTION

– The electrical installation should have a multiple separation system with contacts opening at least 3mm.

– For continued protection against possible electric shock this unit is to be mounted to the base in accordance with the installation instructions.

1). The protection of the system should be based on a residual current device (RCD) with a rated tripping current not exceeding 30mA. The supply cable should comply with EMC standards.

2). Single-phase motors have built-in thermal protection. When the pump run under abnormal condition and caused the thermal protector to work, please cut off the pump power if it is at the low speed (1450r/min) and plug in 1 minute later. If the pump is at the high speed (2900r/min), It will start work again when the thermal protector reset automatically as the motor temperature drops to a certain degree.

– The diagrams in fig. (1) correct electrical connection for high speed, The diagrams in Fig.(2), The connection of 2 speed pumps: When the pumps run at high speed, the low speed power cord (brown) can't be plugged in, At the same reason, when the pumps run at low speed, the high speed power cord (blue) also can't be plugged in. Correct electrical connection for low speed. The electric connection must be carried out by qualified staff following strictly the "EN60335-2-60" standard.

– Be sure that the earth cable connection is correctly made.

– Be sure that the equipotential connection between the bath and the pump is correctly made.

– Wires serving as equipotential bonding conductors shall have a cross sectional area between 2.5 mm<sup>2</sup> and 6 mm<sup>2</sup> and shall be equipped with the terminal suitable receptacle.

## 5.CONTROLS PRIOR TO INITIAL START-UP

– Verify that the pump shaft turns freely.

– Check that the mains voltage and frequency are according to the name plate.

- The hydromassage assembly should be equipped with a system to prevent the pump from starting up if a minimum water level is not present.
- Check the rotating direction of the motor, which should concur with that indicated on the fan cover.
- If the motor does not start up, try to locate the problem in the table of most common faults and their possible solutions that is provided further on.
- **THE PUMP SHOULD NEVER OPERATE DRY.**

### 6.START-UP

- Start electrically the pump only when the suction and discharge pipes are connected to the corresponding inlets and outlets.
- Apply voltage to the motor and suitably adjust the jets to obtain the desired flow.

### 7.MAINTENANCE AND CLEAN !

- Our pumps for hydromassage facilities do not require any special maintenance or programming. If the pump will be idle for a long period of time, it is recommended to disassemble, clean and store it in a dry, well ventilated place. If the supply cord is damaged, it must be replaced by the manufacturer or its service agent or a similarly qualified person to a hazard.

### 8.TROUBLE SHOOTING GUIDE

SYMPTOM	POSSIBLE CAUSE	CHECK
PUMP DOES NO TURN	NO POWER TO PUMP	-Incoming power to the pump? -Is circuit breaker on? -Is GFCI operating properly? -Is the air switch plugged in?
	AIR SWITCH DISCONNECTED	-Is the air switch hose connected to the pump? -Is the air switch hose connected to the actuator button on the tub deck?
PUMP NOT PUMPING PROPERLY	BLOCKAGE OR LEAK	-Jets should be pointed away from the suction inlet so air is not forced into pump suction. -Is the in tub suction inlet blocked or covered? -Is there any debris in the pump housing? -Is there a leak in the piping or the pump?
	LOW VOLTAGE	-Is the proper voltage applied to the pump? -Is there an extension cord being used?

### 9.INSTALLATION DIAGRAM

As the colours of the wires in the mains lead of this appliance may not correspond with the coloured markings identifying the terminals in your connection unit proceed as follows.

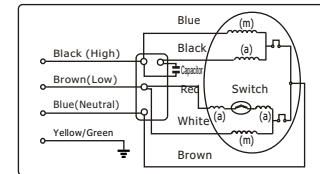

Fig.1

The wire which is coloured green-and-yellow must be connected to the terminal in the connection unit which is marked with the letter E or by the earth symbol or coloured green or green -and-yellow.

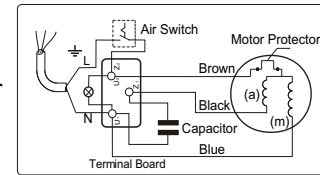

Fig.2

Brown wire and Blue wire connected with power supply is low speed.

Black wire and Blue wire connected with power supply is high speed.

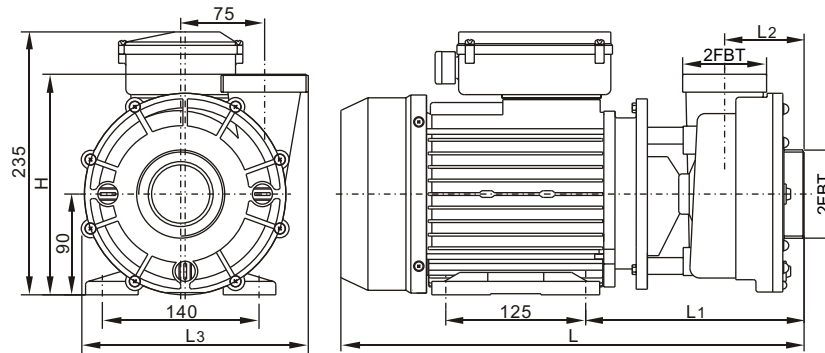

Fig.3

Model	Power(P)		L	L1	L2	L3	H
	kW	HP					
WP200-I	1.5	2.0	415	195	71	202	197
WP250-I	1.85	2.5					
WP300-I	2.2	3.0					
WP400-I	3.0	4.0					
WP200-II	(Low speed) 0.35	3/8	431	195	71	202	197
	(high speed) 1.50	2.0					
WP250-II	(Low speed) 0.40	1/2					
	(high speed) 1.85	2.5					
WP300-II	(Low speed) 0.45	5/8					
	(high speed) 2.20	3.0					

